

STRUCTURAL TUBE DETAILS

I-BEAM DETAILS

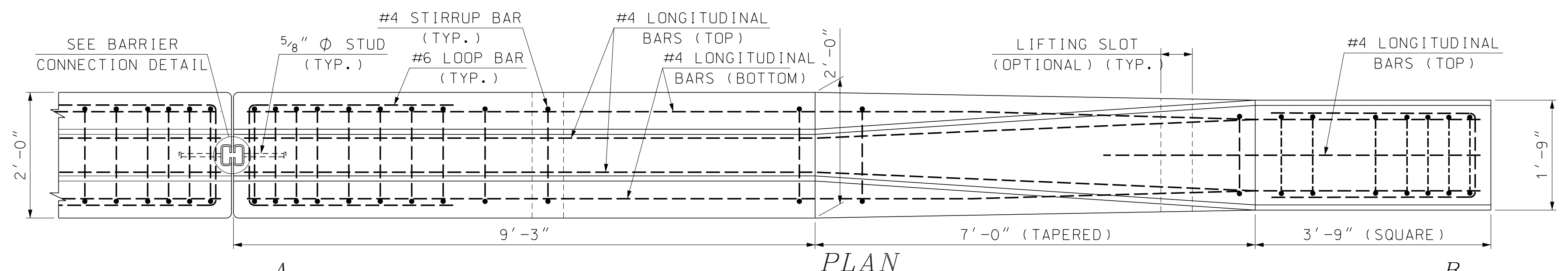

PLAN

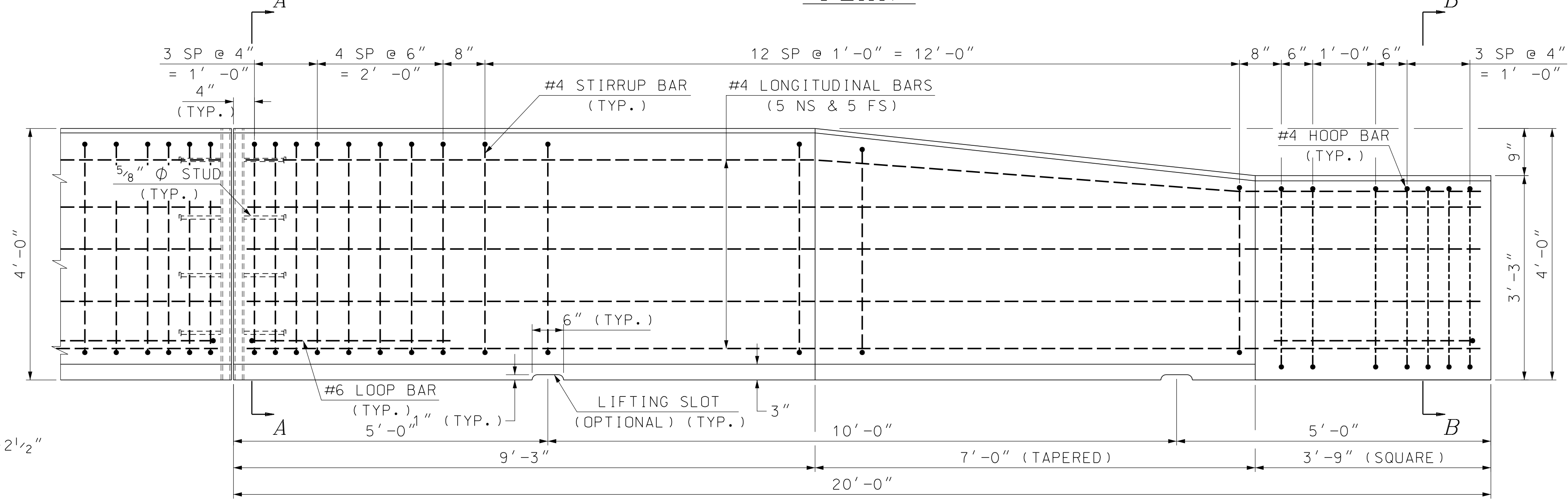

ELEVATION

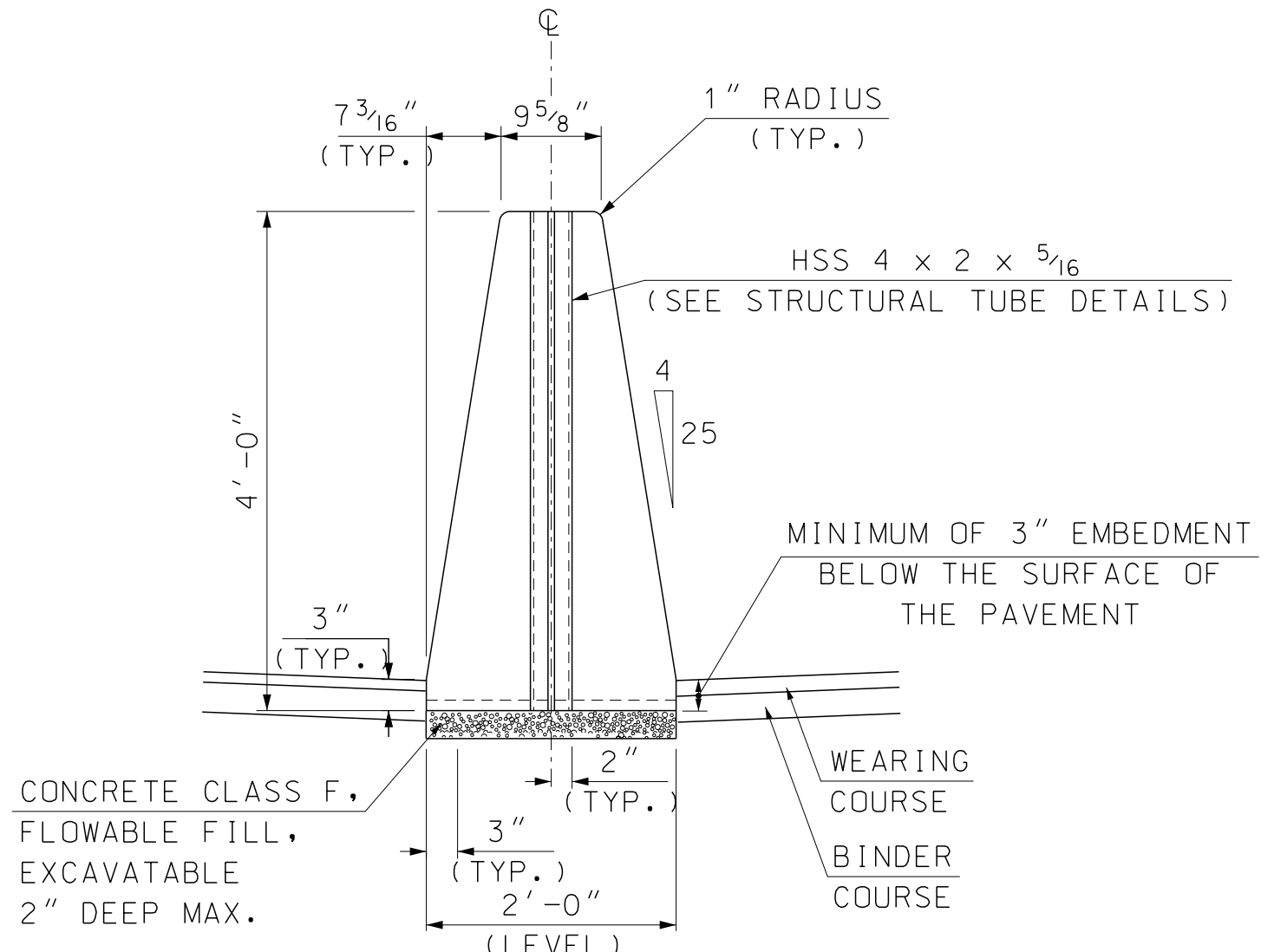

END VIEW (MASONRY)

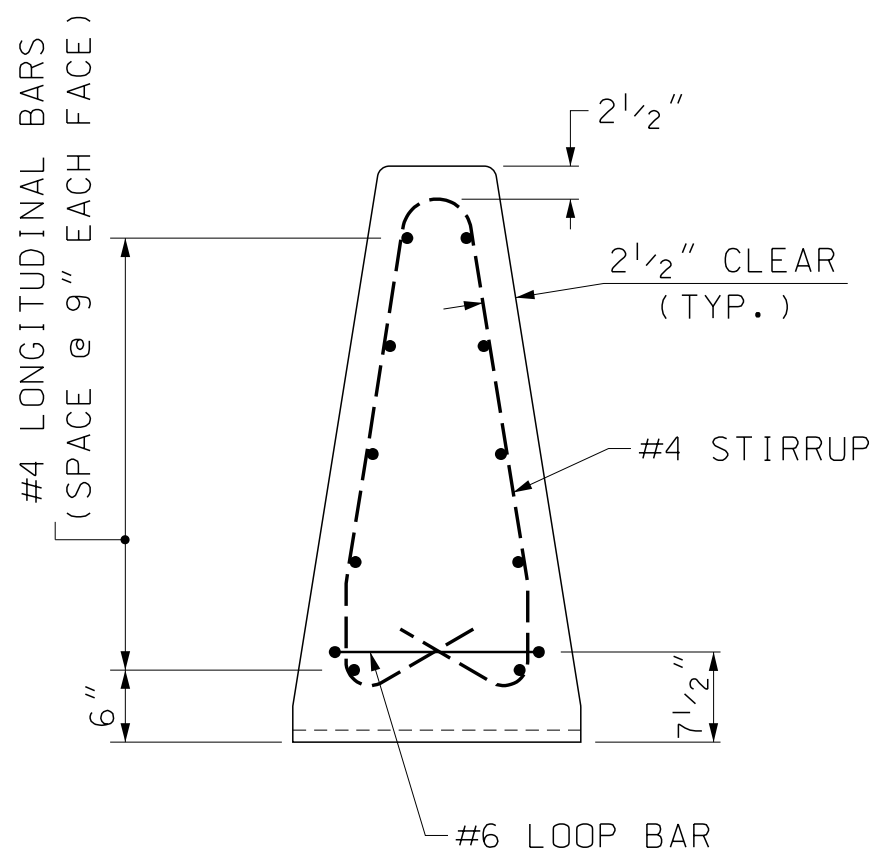

SECTION B-B (MASONRY & REINFORCEMENT)

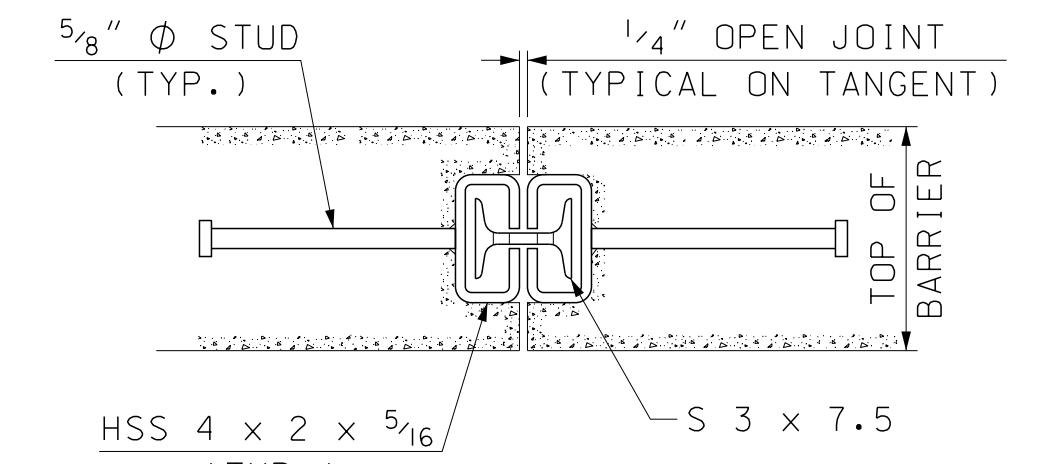

BARRIER CONNECTION DETAIL

GENERAL NOTES

1. THE CONCRETE BARRIER DETAILS, AS SHOWN ON THIS SHEET, ARE IN COMPLIANCE WITH THE REQUIREMENTS OF NCHRP REPORT 350, TL 4.
2. I-BEAMS AND STRUCTURAL TUBES SHALL BE GALVANIZED AFTER FABRICATION.
3. STUD WELDING SHALL BE IN ACCORDANCE WITH ITEM 547.
4. SLOTS IN STRUCTURAL TUBES SHALL BE CUT WITH MECHANICALLY GUIDED MEANS TO A SMOOTH, UNIFORM SURFACE MEETING A SURFACE ROUGHNESS OF 1000 MICROINCHES OR BETTER (ANSI B46.1).
5. PAID FOR UNDER APPROPRIATE 606 ITEMS, OR AS SHOWN ON PLANS.

MATERIAL NOTES

1. THE BARRIERS SHALL BE LIGHT COLORED CLASS "AA" CONCRETE HAVING A MINIMUM 28 DAY COMPRESSION STRENGTH OF 4,000 PSI. BARRIERS SHALL HAVE A SMOOTH UNIFORM SURFACE FREE OF DEFECTS AND IRREGULARITIES. CASTING DATE SHALL BE SHOWN ON BARRIER. ALL EXPOSED EDGES OF CONCRETE SHALL BE CHAMFERED 3/4", UNLESS NOTED OTHERWISE.
2. ALL REINFORCING STEEL SHALL BE AASHTO M31 (ASTM-A615) GRADE 60, EPOXY COATED. REINFORCEMENT SHOWN IS THE MINIMUM REQUIRED.
3. EACH BARRIER UNIT SHALL INCLUDE ONE S 3 x 7.5 AS SHOWN ON THIS PLAN SHEET.
4. SHOP DRAWINGS, SHALL INCLUDE REINFORCING SCHEDULE.
5. LEVELING PADS OR SHIMMING MATERIAL SHALL BE SUBSIDIARY TO THE BARRIER ITEM.

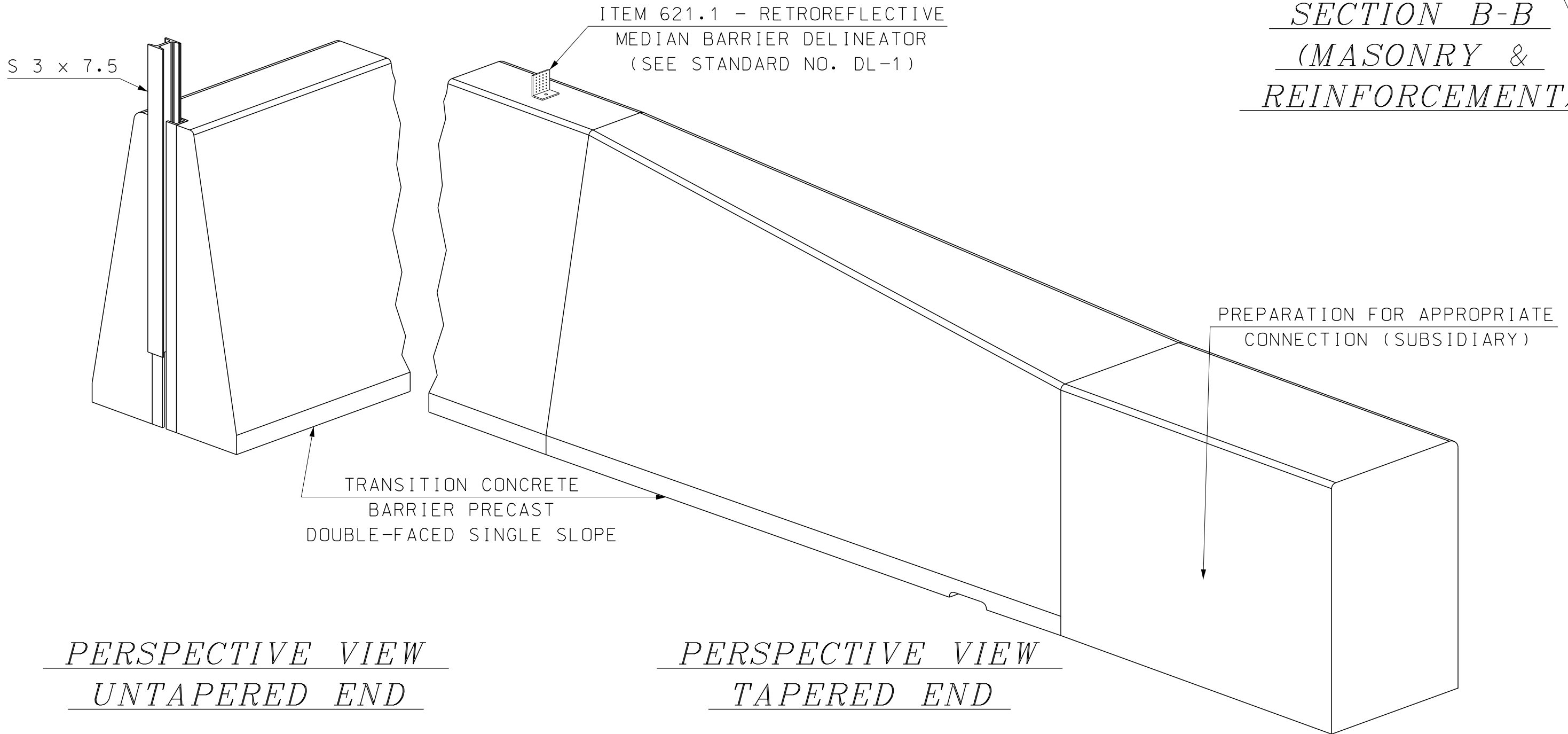

PERSPECTIVE VIEW UNTAPERED END

PERSPECTIVE VIEW TAPERED END

GUARDRAIL STANDARD
TRANSITION
CONCRETE BARRIER PRECAST
DOUBLE-FACED SINGLE SLOPE

STANDARD NO. GR-20
REVISION DATE
02-26-2010
09-16-2010
11-05-2010
10-30-2012
04-03-2014
*DGN FILE NAME
GR-20

STANDARD PLANS



STANDARD NO. GR-20