

Portsmouth
Memorial
Bridge

Existing Pedestrian Railing

Sidewalk
Panels and
Pedestrian
Railings

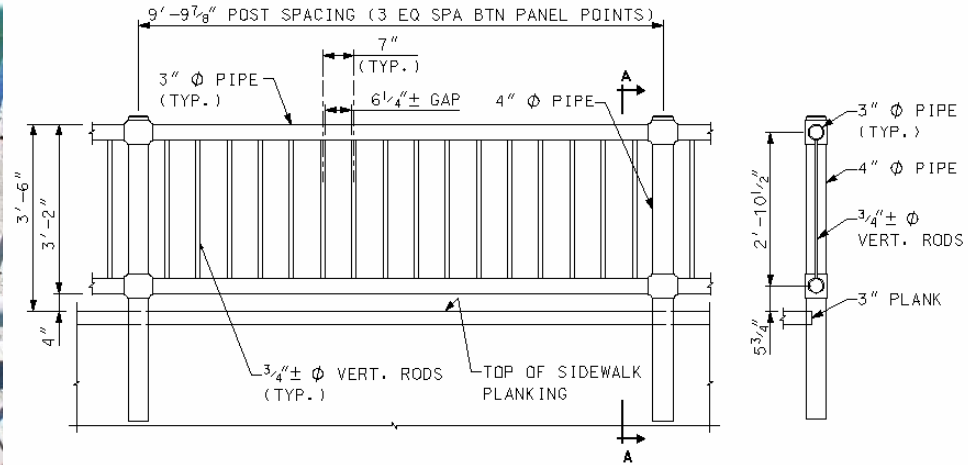

Photo



Rendering

DRAFT



Portsmouth
Memorial
Bridge

Sidewalk
Panels and
Pedestrian
Railings

Option 1 Pedestrian Railing

- Most similar to existing railing
- Maintains 4" diameter posts and 3" diameter rails
- Maintains ~10 ft. post spacing
- Maintains 3'-6" pedestrian railing height

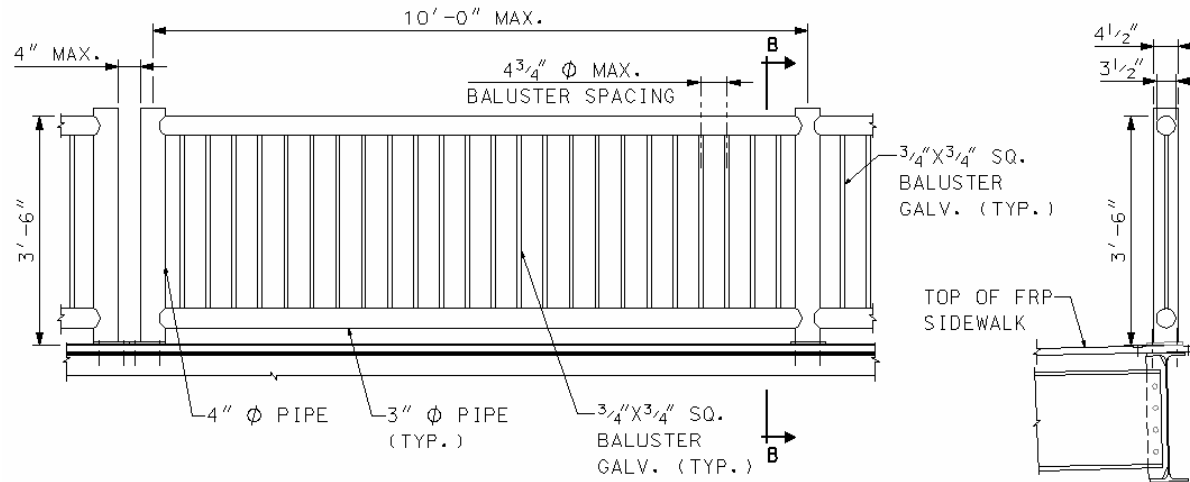

DRAFT



Portsmouth
Memorial
Bridge

Sidewalk
Panels and
Pedestrian
Railings

Option 2 Pedestrian Railing

- Slender 2 1/2" diameter posts and rails
- 5 ft. post spacing
- Maintain 3'-6" pedestrian railing height

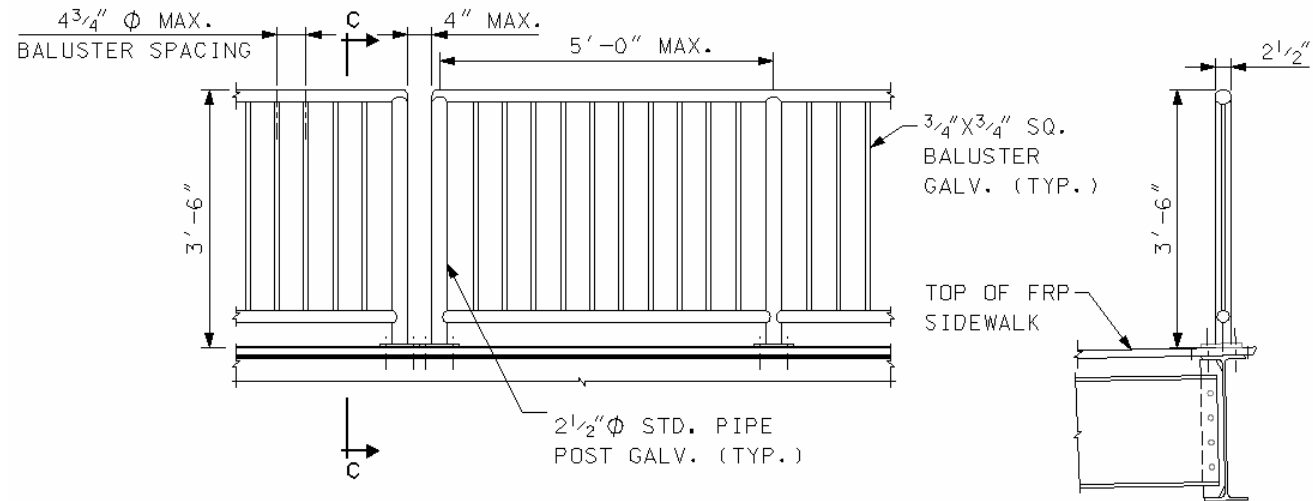

DRAFT

HNTB

Portsmouth Memorial Bridge

Roadway Barrier

- Existing Cross Section and Bridge Railing
- Proposed NHDOT T2 Bridge Railing
 - Recommend chamfering T2 posts similar to existing to protect pedestrians and bicyclists from blunt edges

Roadway Barrier

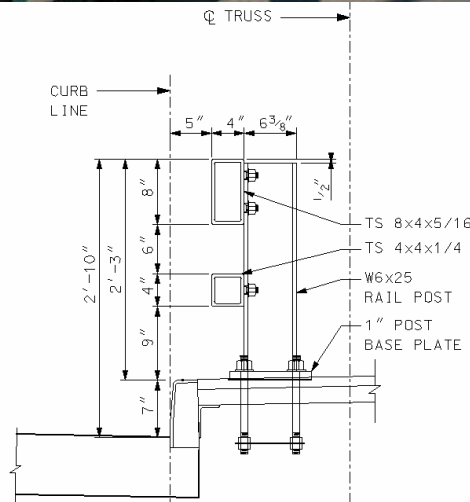
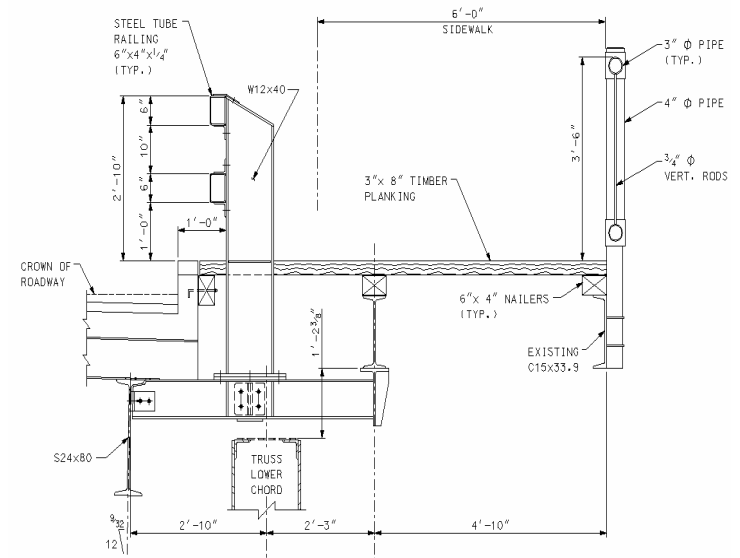

DRAFT

