

- ### EXPANSION JOINT NOTES
- (1) EXPANSION JOINT STEEL SHALL BE AASHTO M270 GRADE 50W (ASTM A709 GRADE 50W), EXCEPT AS OTHERWISE ALLOWED. THE ENTIRE ASSEMBLY, INCLUDING ELASTOMERIC SEAL, SHALL BE PAID FOR AS ITEM 561.110, PREFABRICATED EXPANSION JOINT, TYPE A (F).
 - (2) SPLICES FOR EXPANSION JOINT STEEL SHALL DEVELOP FULL STRENGTH.
 - (3) THE EXPANSION JOINT SHALL BE PRESET TO THE TEMPERATURE ANTICIPATED AT THE TIME OF INSTALLATION. FINAL SETTING IN THE FIELD SHALL BE DETERMINED BY THE CONTRACT ADMINISTRATOR (SEE TEMPERATURE ADJUSTMENT TABLE).
 - (4) ELASTOMERIC STRIP SEAL SHALL BE FURNISHED IN ONE CONTINUOUS LENGTH. NO SPLICES WILL BE ALLOWED.
 - (5) JOINT SUPPORT PLATES SHALL BE SHOP WELDED TO THE EXPANSION JOINT STEEL AND SHALL BE VERTICAL AFTER THE JOINT ASSEMBLY HAS BEEN ADJUSTED FOR ROADWAY CROSS-SLOPE AND GRADE.
 - (6) THE EXPANSION JOINT ASSEMBLY SHALL BE INSTALLED ONLY AFTER BOTH ABUTMENTS HAVE BEEN BACKFILLED TO WITHIN 3'-0" OF FINISHED GRADE.
 - (7) IMMEDIATELY AFTER THE JOINT HAS BEEN SECURED TO THE STRUCTURAL STEEL AND BACKWALL, REMOVE SHIPPING DEVICES AND GRIND SMOOTH ANY WELDS ON EXPOSED SURFACES. REPAIR ANY DAMAGE TO EXPOSED PAINTED SURFACES WITH ZINC-RICH PRIMER, N.H. 1.60.
 - (8) PROTECT TOP OF EXPANSION JOINT DURING PLACEMENT OF CONCRETE AND BITUMINOUS PAVEMENT.
 - (9) THE ELASTOMERIC STRIP SEAL SHALL HAVE A MINIMUM RANGE OF MOVEMENT OF XX INCHES.
 - (10) NO "LOW PROFILE" STEEL EXTRUSIONS SHALL BE ALLOWED.
 - (11) ELEVATIONS SHOWN AT TOP OF ANGLES ARE 1/8" LOWER THAN PROPOSED FINISHED ROADWAY GRADE.

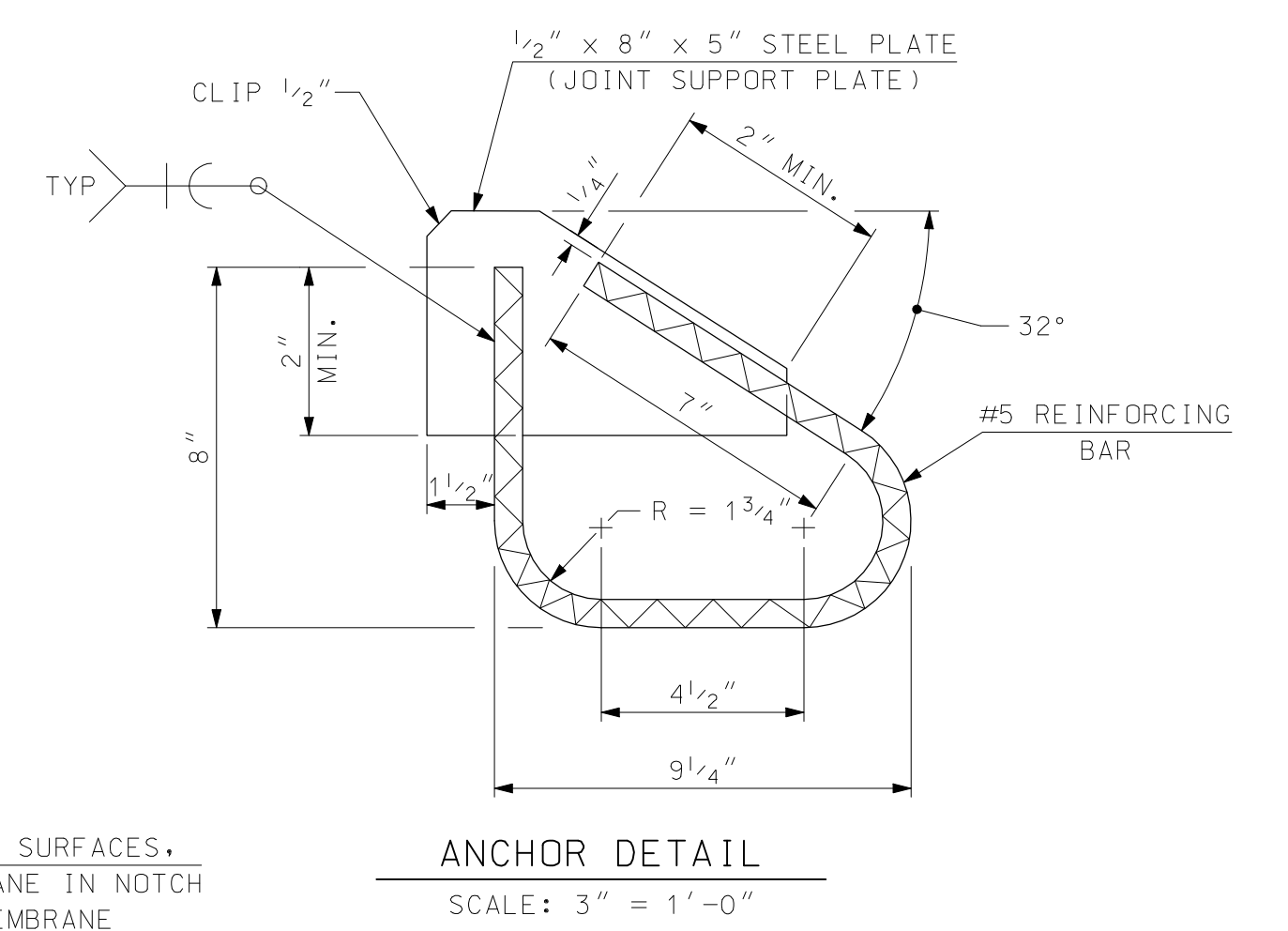
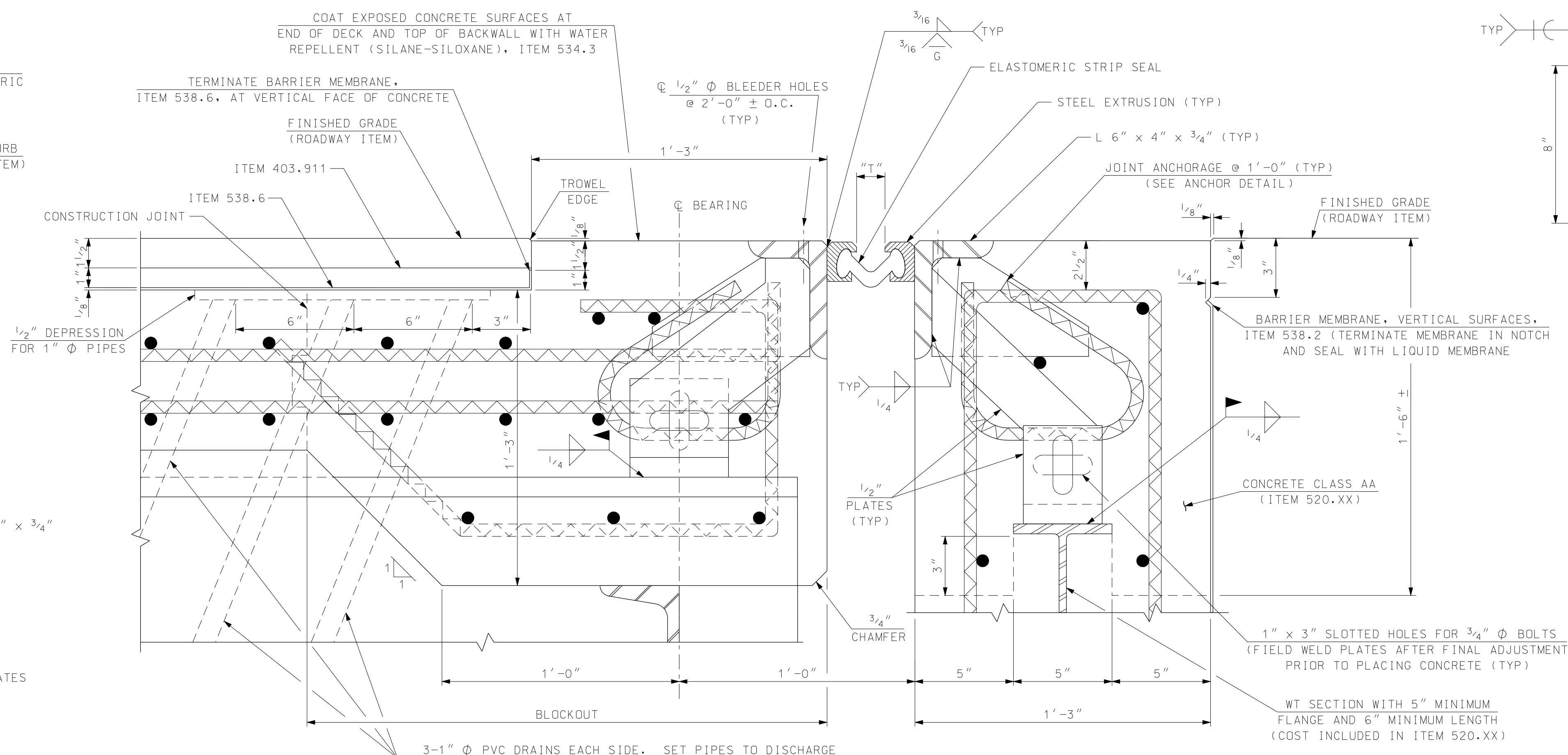
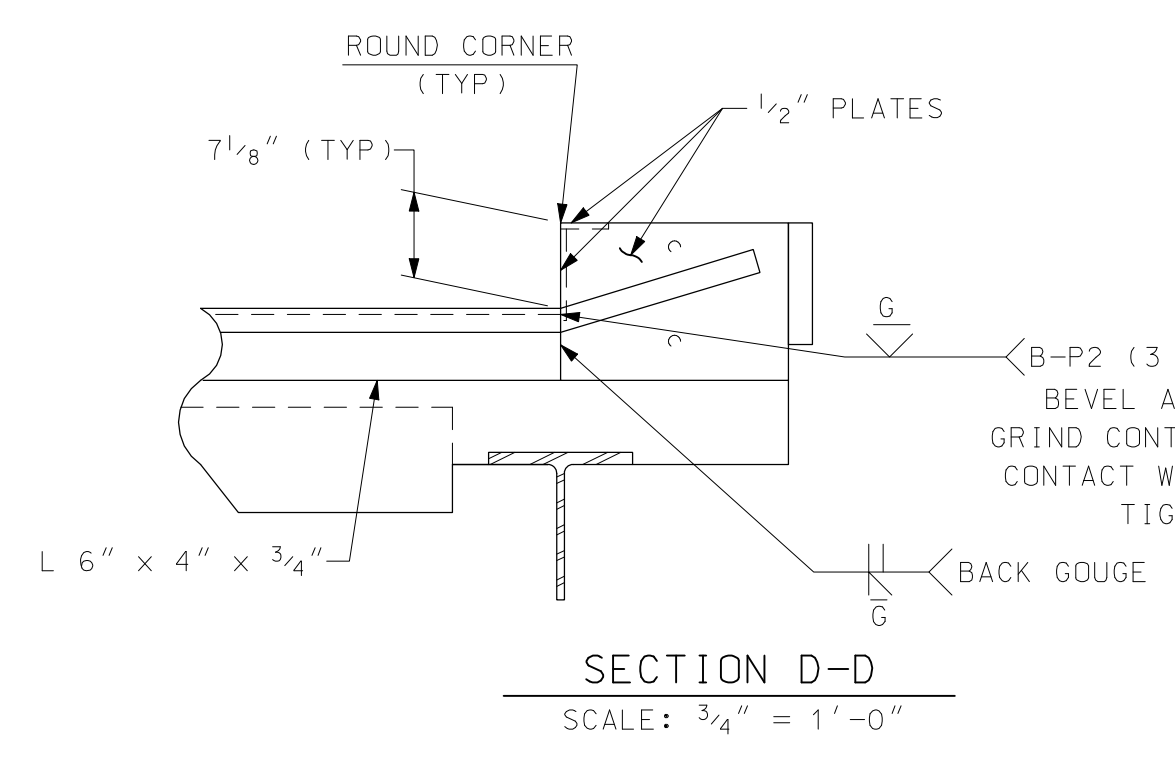
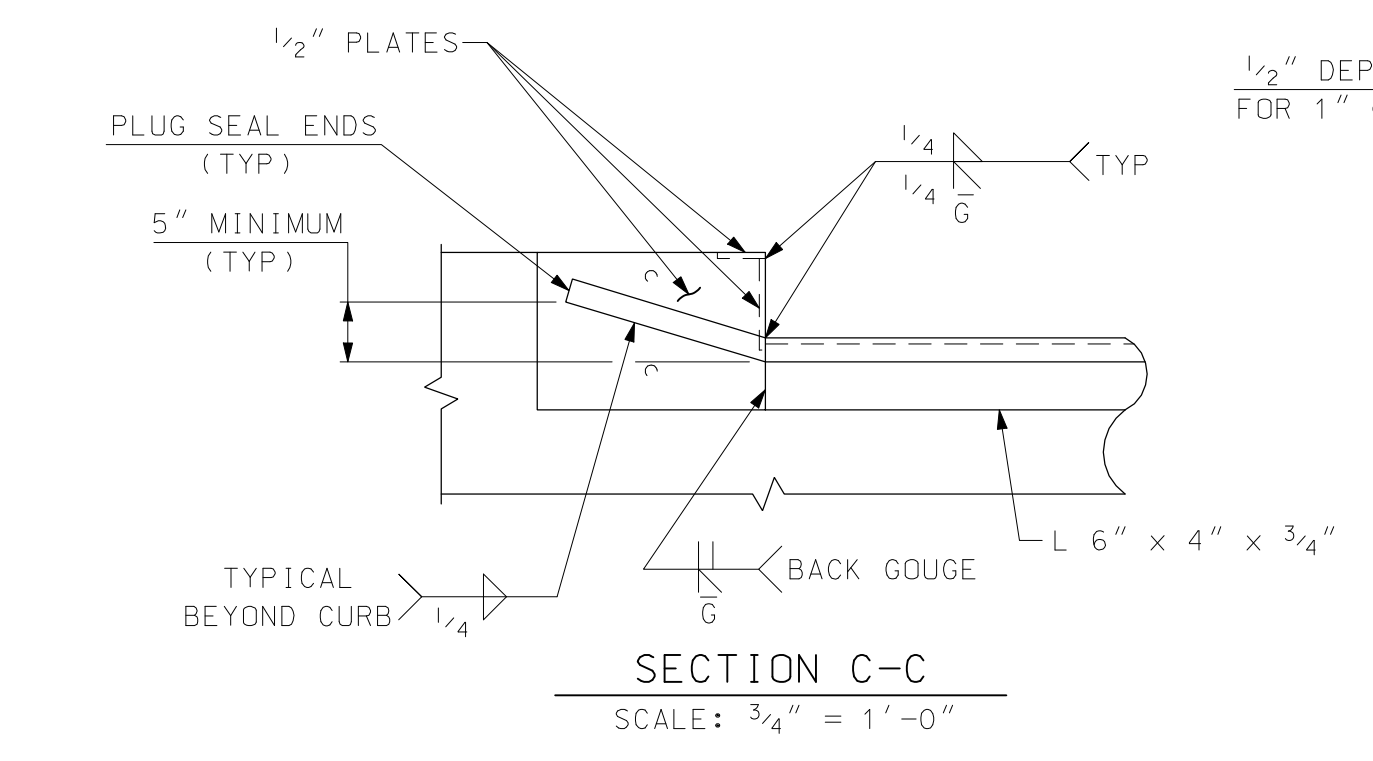
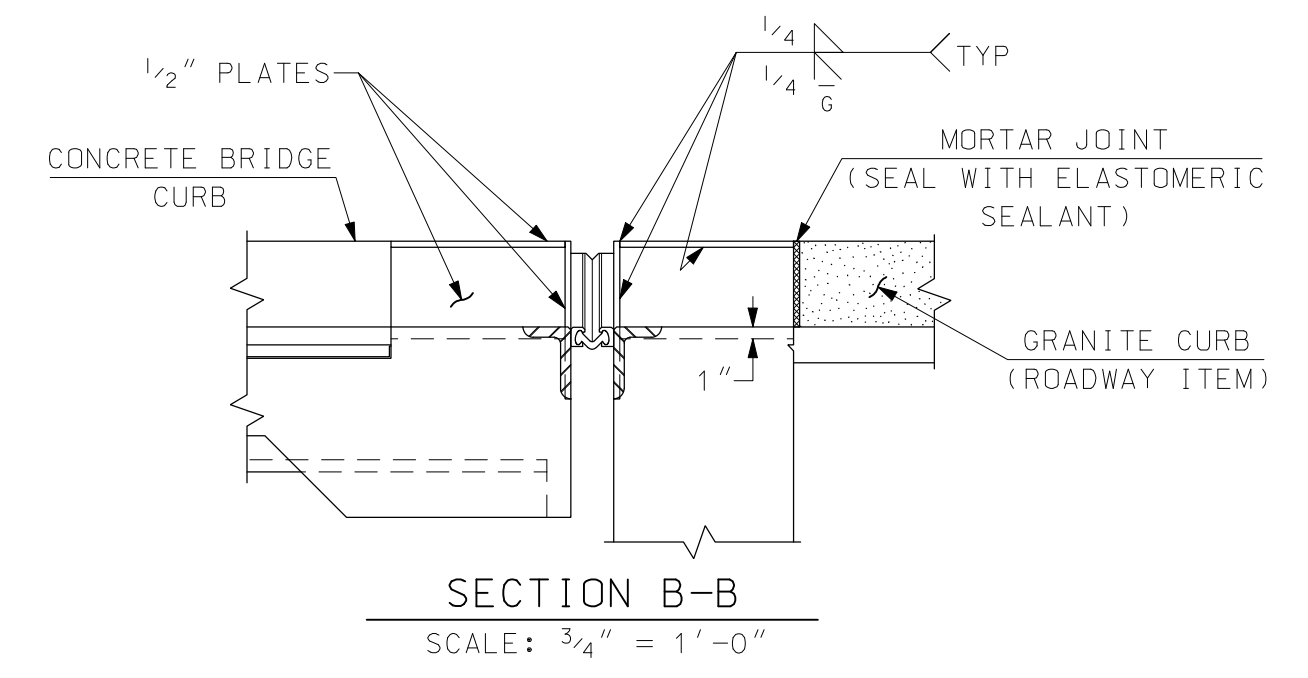

TEMPERATURE ADJUSTMENT TABLE	
TEMPERATURE	"T"
15°F	X"
30°F	X"
45°F	X"
60°F	X"
75°F	X"
90°F	X"

"T" DIMENSIONS ARE PERPENDICULAR TO FACE OF BACKWALL

STATE OF NEW HAMPSHIRE									
DEPARTMENT OF TRANSPORTATION * BUREAU OF BRIDGE DESIGN									
TOWN		BRIDGE NO.				STATE PROJECT			
LOCATION									
STRIP SEAL EXPANSION JOINT (SKEWED LEFT)									
REVISIONS AFTER PROPOSAL		BY		DATE		BY		DATE	
		NHDOT		7/07		NHDOT		6/92	
DRAWN		PJP		7/07		CHECKED		ACJ	
QUANTITIES						CHECKED			
ISSUE DATE		FEDERAL PROJECT NO.				SHEET NO.		TOTAL SHEETS	
REV. DATE									

SUBDIRECTORY	DGN LOCATOR	SHEET SCALE
English/EXP-JTS	TYPE A-LT	AS NOTED